

NETMAX™

NETWORKED MATRIX SYSTEM

IRISNet

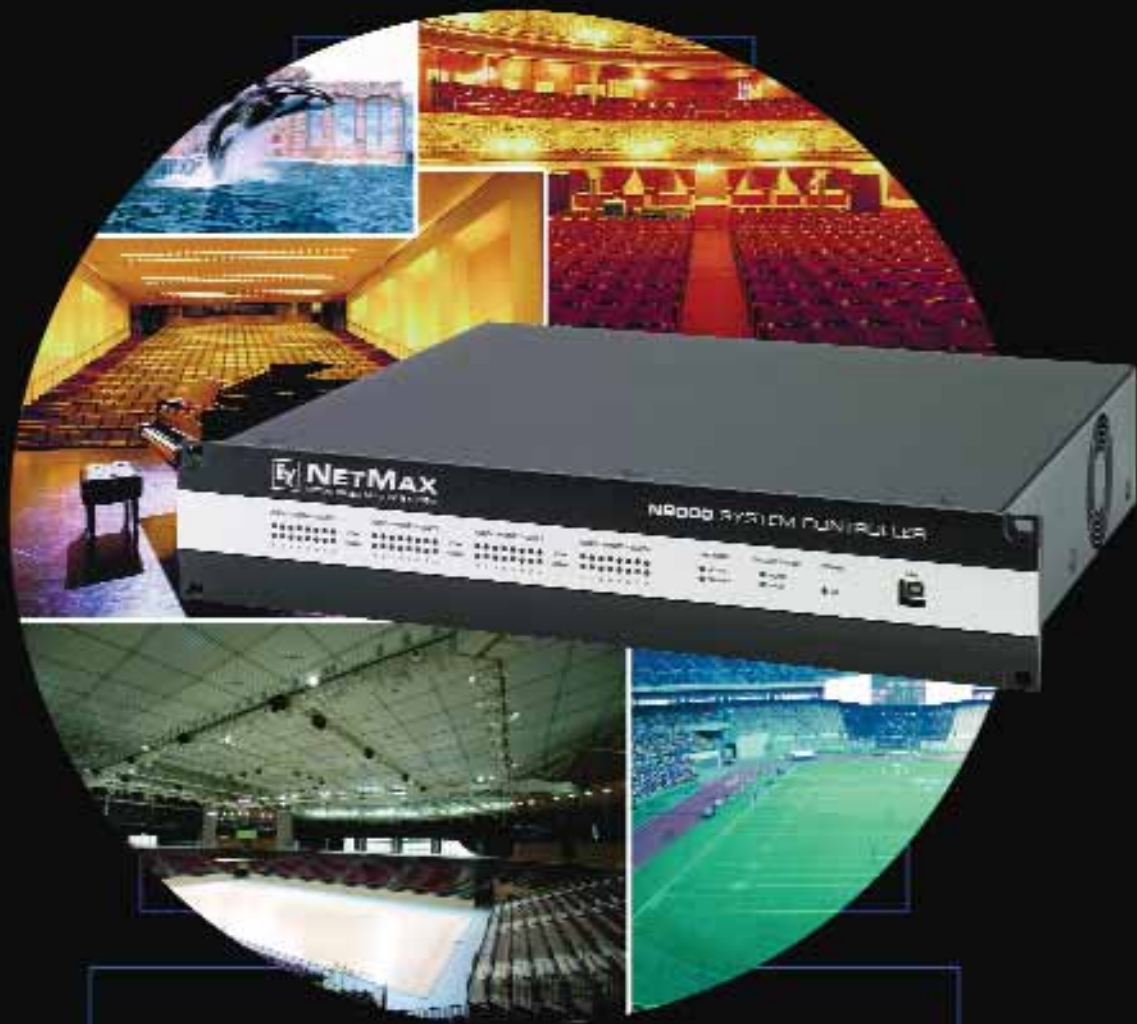

NETMAX

NETWORKED MATRIX SYSTEM



Integration
Flexibility
Performance

. . . Only EV can offer it ALL.



IRIS - Net™ – The first comprehensive audio control solution from front to back

From the introduction of the first IRIS (Intelligent Remote Integrated Supervision) software platform for amplifiers in 2002, EV has been developing a robust audio control protocol and new innovative audio hardware. The first was the RL line of remote controlled amplifier products. These amplifiers offered an amazing level of user control and monitoring, which brought reliability and ease of use to a wide range of users. Now EV is introducing the NetMax™ N8000, a comprehensive digital audio system controller — the next link in the IRIS-Net™ audio processing chain.

IRIS-Net™ is EV's answer to the ever-increasing complexity of audio system designs. It is a comprehensive software platform, which encompasses a huge array of control options. All aspects of the audio chain are under its supervision and control. The key areas of signal processing, supervision and signal routing are all manipulated under its shell.

The new NetMax™ N8000 is the central player in the IRIS-Net™ solution. It offers an extremely flexible hardware platform that allows for field level customization of the unit to nearly any application. This customization goes far beyond what is available today from other platforms. Everything from the matrix size and configuration to the processing power can be customized in the field, making it easy to design the best solution value for the customer.

Distributed vs. Central processing – The N8000 and IRIS-Net™ gives you both!

Now you don't have to make the choice as to where your processing power resides. IRIS-Net™ gives you the ability to choose BOTH! IRIS-Net™ enables you to process all or part of the audio signal in a central component like the NetMax™ N8000 or to conduct the processing and supervision remotely at the amplifier. This gives the system designer incredible flexibility in designing the system. You can now design the system for the ultimate in reliability or design for efficiency and value. The IRIS-Net™ solution gives you all the hardware and software pieces to accomplish both objectives.

Open Architecture – Extensively Tested

The IRIS-Net™ software platform has been extensively tested in a variety of venues. Even prior to its introduction the system hardware and software underwent extensive testing and scrutiny. The software interface and hardware component design were made with the user and designer in mind. The open architecture of the hardware and IRIS-Net™ user protocol allow for the seamless functioning of external devices within IRIS-Net™ and its hardware components.

NETMAX

NETWORKED MATRIX SYSTEM

The N8000 - A Comprehensive DSP Hardware Platform

The EV NetMax™ N8000 is an extremely flexible audio control processor for a wide range of applications. Presented in a compact 2RU configuration, you can configure the N8000 a number of ways to fit the need at hand. By simply selecting the right combination of I/O cards, the N8000 matrix can be configured IN THE FIELD to one of 6 layouts. In addition, up to a full 32 channels of digital audio are available when you can add CobraNet™ functionality to any of these configurations for extended flexibility.

Superior Audio Performance

The N8000 provides the same legendary audio dynamic range as our amplifiers and signal processors. Superior A/D and D/A conversion technology and wideband electronics ensure that the NetMax™ N8000 will be transparent in the audio chain.

Optional extended processing power Up To 1 000 MIPS

The N8000's processing power can be enhanced by simply plugging in an additional processor. This comes in handy if your application calls for future expansion. You only need to purchase the processing power needed today, knowing that the system can be upgraded at any time.

Multiple N8000 units can be networked together to provide an extended "super matrix" for complex audio processing tasks. Several examples of the power of a multi-processor NetMax™ system are shown in the following pages.

Easy Interface To The Outside World

The N8000 can be configured from the web, an Ethernet connection using IRIS-Net™, an RS-232 interface or a common USB link. In addition, the N8000 can talk through its integrated CAN bus with any compatible IRIS-Net™ hardware such as the Electro-Voice RL/RT amplifier series. For even more flexibility the N8000 comes equipped with a GPIO network so it can control and be controlled through simple logic signals and contact closures.

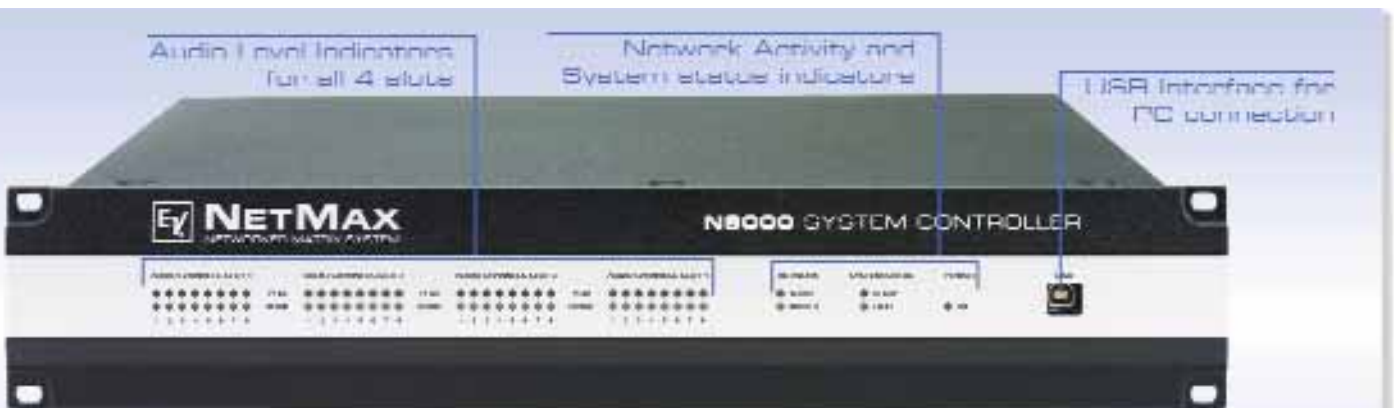

4 input or output card slots. Each accommodates a single 8 channel input or output card



Beyond Audio Processing

In addition to the sophisticated audio functions of the NetMax™ N8000, it is also equipped with diverse control functions. The clock /calendar scheduling system makes it possible to program one-time or recurring events. The schedule options are varied and can be set to occur annually, monthly, weekly, daily, hourly or even within smaller time intervals. In addition, daily programs can be set up.

With the event control, reactions to certain events or system states can be configured including changing entire system parameters at the touch of a button or schedule.

Full System Monitoring

Faults in the device or in the complete NetMax™ system are detected automatically and can be displayed on the PC screen or transmitted to external sites if necessary.

Faults and other events are recorded in an internal log file with date and time. In addition, you can define which types of errors or events should be recorded. The log can be read out and displayed on the screen at any time. When used in conjunction with Electro-Voice RL series amplifiers, the NetMax™ system has the ability to monitor the amplifier, speaker line and speaker through a sophisticated impedance monitoring protocol.

SOFTWARE



Comprehensive Control

IRIS-Net™ provides the system designer with a comprehensive and easy-to-use interface to control any aspect of the NetMax™ N8000 digital matrix or RL amplifier. From assigning macros, setting schedules, running system checks or setting up channel equalization it can all be done from this one interface.



Comprehensive DSP control

IRIS-Net™ provides a broad array of DSP tools that enable the designer to control nearly any aspect of the audio signal, filters, delays and EQ parameters, along with many other functions that are easily available and can be quickly configured.

Comprehensive Macro Functionality

In the NetMax™ N8000 complex operations can be integrated into single functions. For example, several functions combined into a single scene preset and can be changed manually or automatically at any time.

Visually Based Signal Routing

The main design module gives a comprehensive view of the overall system design as it is being built. You can “drill down” in each element to control all functions in the unit.

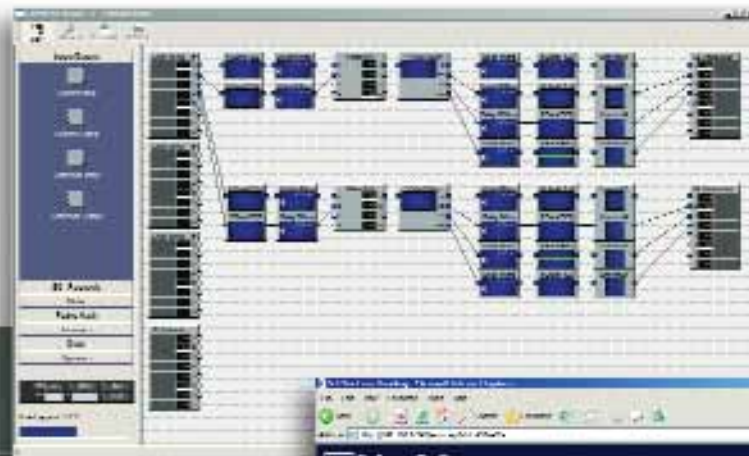

N8000 SYSTEM CONTROLLER



The N8000 Built In Browser Interface

The N8000 comes equipped with a built in graphical control interface accessible through any web browser. This interface allows for full system control of a variety of system control functions and parameters. The interface is also equipped with sophisticated security protection to protect against unauthorized operation.

APPLICATIONS



House of Worship

In this example, audio signal from the main Front of House mixer is routed and processed separately by the NetMax™ N8000 for main loudspeakers, stage monitors, under balconies and distributed lobby speakers as well as assistive listening devices. All loudspeakers are powered using EV CPS Series amplifiers. The N8000 allows for storage and recall of different routing, level and EQ settings for a variety of events via the control PC.

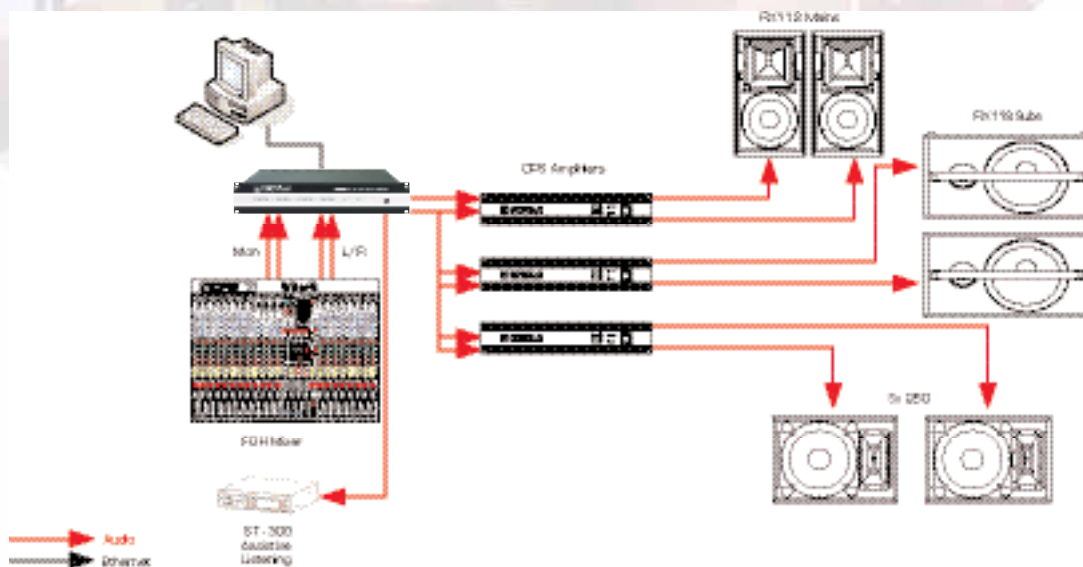

Concert Hall

Theaters and performance venues present unique signal processing challenges. The many types of loudspeakers and locations can require a very high number of DSP channels for signal processing. NetMax™ allows the flexibility to address the DSP needs for each loudspeaker type and position. IRIS-Net™ can be configured with multiple GUI layers that can be password protected to only allow access to specific areas of the DSP chain. This allows guest engineers to adjust the PA system to suit their needs without having access to critical DSP processing like crossovers or limiters.

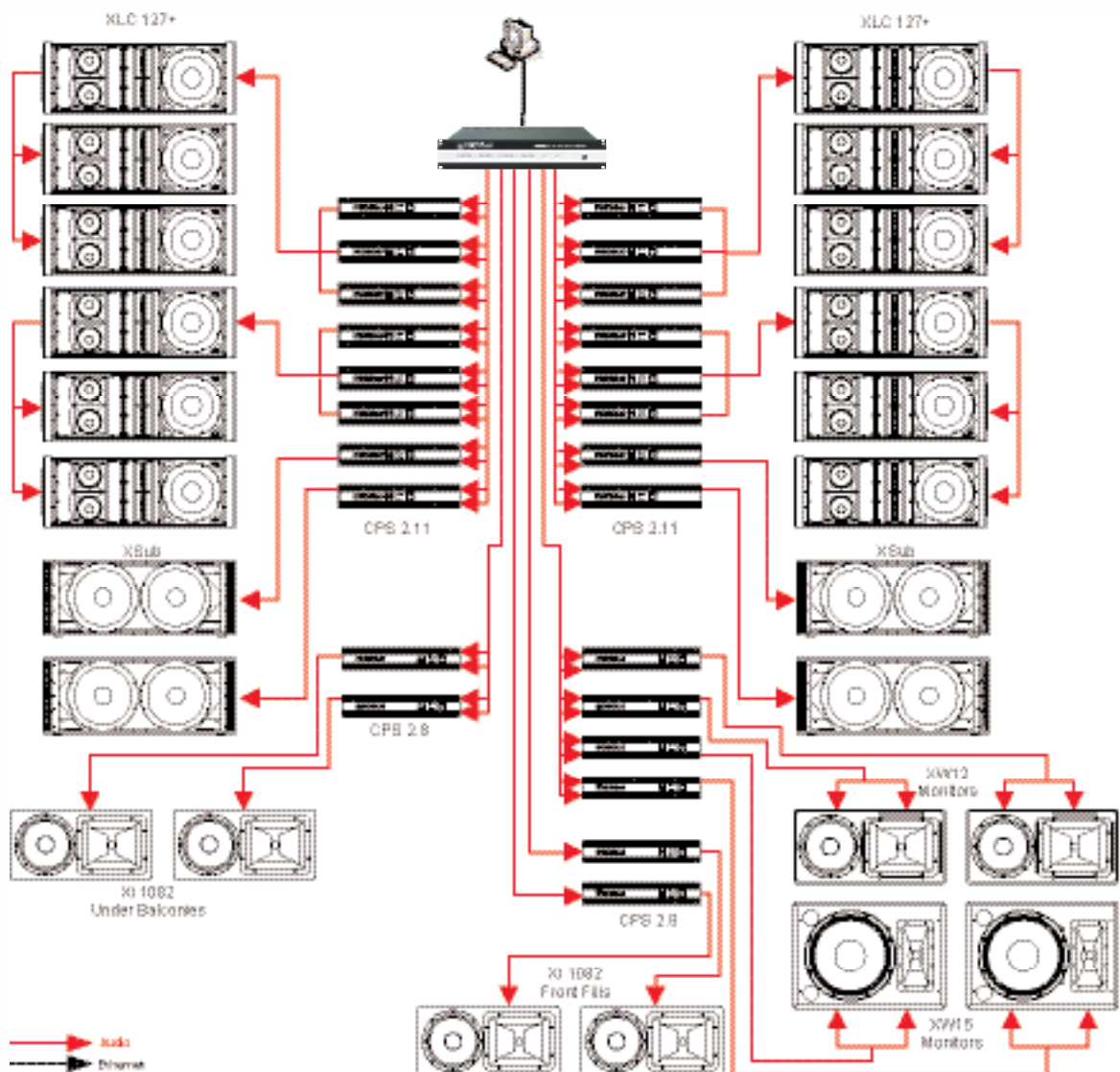

APPLICATIONS



Hotel / Casino

In casinos and similar venues, routing flexibility, supervision and reliability are key aspects of a sound system. NetMax™ allows a variety of signals to be routed to any combination of zones within the casino via CobraNet™, each with individual DSP. Using managed switches allows the CobraNet™ and Ethernet to be configured in a ring topology for additional redundancy. A contact closure from the fire alarm panel allows muting of all sound system loudspeakers in the event of an emergency. Using NetMax™ in conjunction with the Precision Series Remote Control amplifiers allows real-time monitoring of all system components, including electronics, cable and loudspeakers remotely from a single control PC. In the theater, another PC is connected via a UCC-1 to allow control, monitoring and supervision of the theater's PA system in parallel with the main control PC.

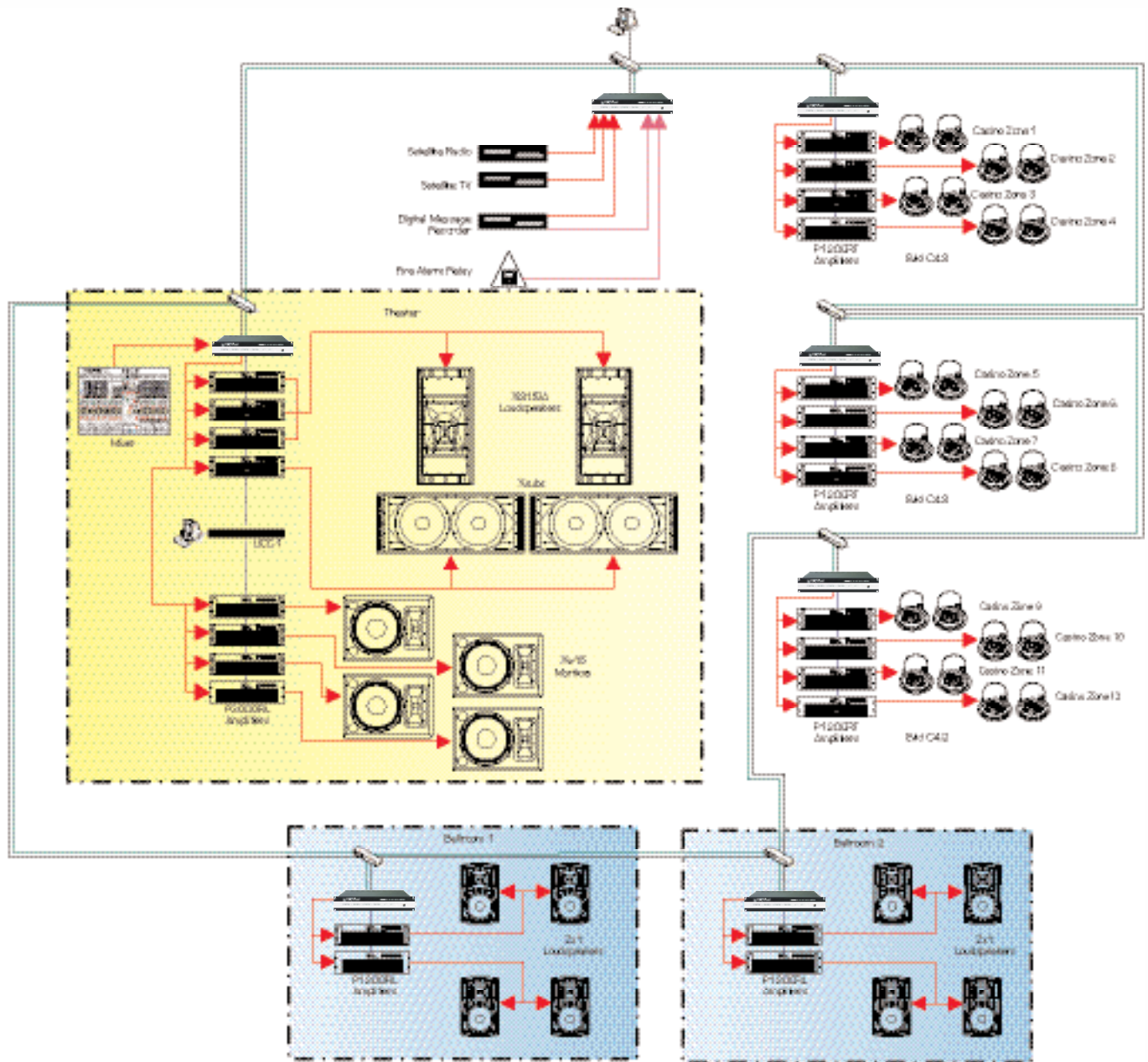

- Ethernet
- Cat5e™
- Audio
- Cat5e
- Cat5e™ Pair
- ... USB

APPLICATIONS



Convention Center

Convention centers have needs for highly reliable distributed sound systems as well as flexibility for redistributing audio for needs that may change on a daily basis. NetMax™ allows large scale distribution and monitoring of audio signals via CobraNet™ to any or all zones, as well as the ability to unite or separate audio paths for room combining scenarios at the touch of a button. Use of the Precision Series Remote Control Amplifiers allow monitoring and control of all audio components in the venue from a single remote location.

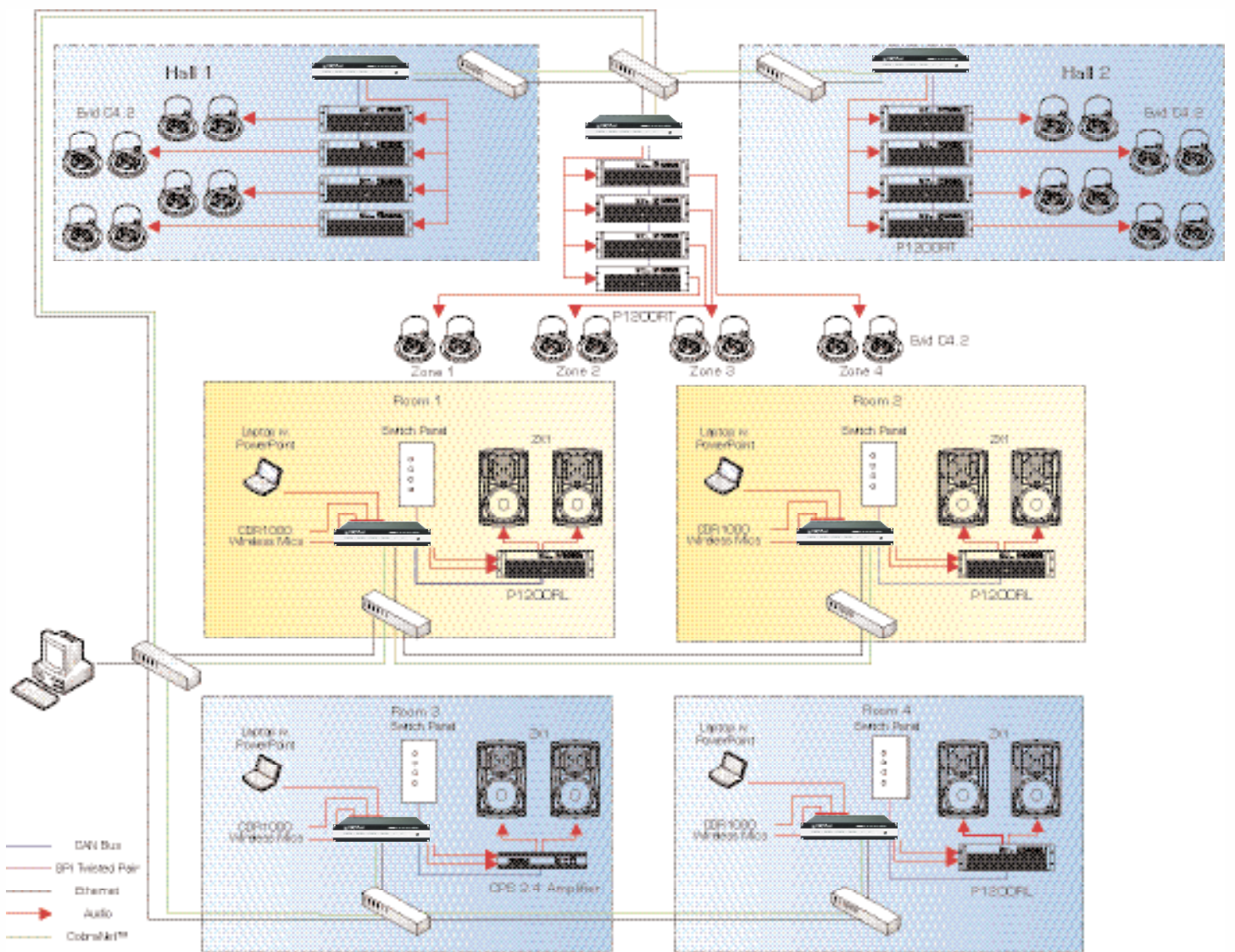

APPLICATIONS



Stadium / Arena

Stadiums have the need for multi-zone sound reinforcement, individual announcements with different priorities and multiple music and advertising signals, all while maintaining high safety and redundancy standards. NetMax™ is able to integrate with Dynacord ProAnnounce™ systems to provide all messaging and paging needs for the PA system. Redundancy is achieved using managed switches with ring capabilities to distribute both primary and secondary CobraNet™ audio and control data. This results in multiple layers of redundancy in the event of a failure.

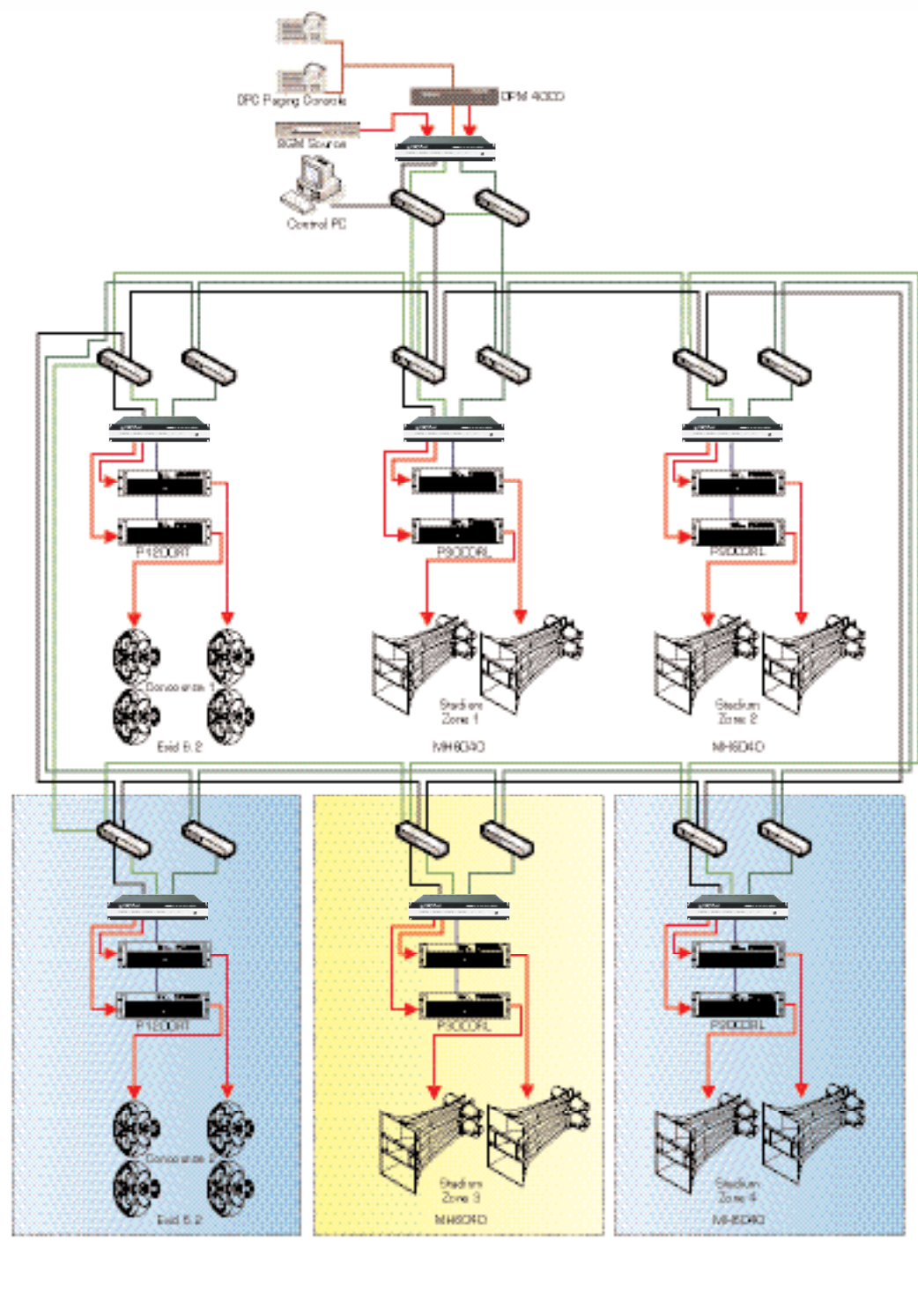

APPLICATIONS



Multimedia

Presentation and training rooms typically feature multiple AV sources that need to be distributed to multiple sources individually or simultaneously. Integration of these different types of sources can be a challenge for an installer, but NetMax™ offers a unique solution to these challenges. In addition to signal processing and distribution, the N8000 offers Ethernet, RS-232, contact closure inputs, contact closure outputs and VCA inputs to allow a high level of integration possibilities with new or existing AV equipment ranging from a relay-driven projector or lighting sources to existing multimedia control systems.

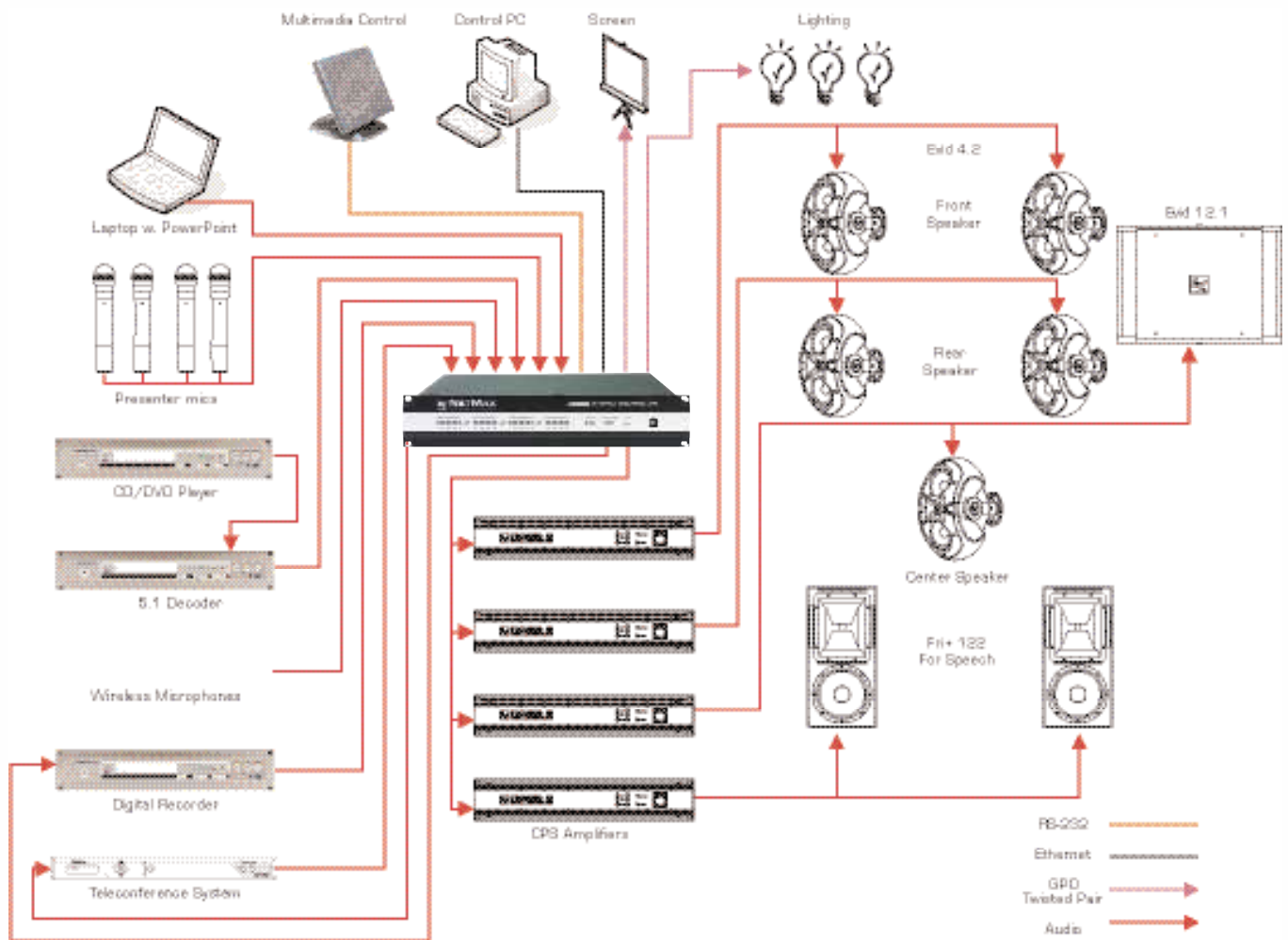

I/O CARDS

Expansion Options

AI-1



The N8000 provides incredible flexibility in system design. Several hardware options are available which enable the N8000 to perform a variety of complex tasks including automatic microphone mixing, extended DSP functions, etc, while maintaining full communication with other IRIS-Net™ equipped components.

AI-1 The AI-1 is an eight-channel analog input module for the NetMax™ System Controller. Audio signals are connected via screw lockable Euro block connectors. A-to-D conversion is handled by high performance linear 24-bit converters. Internally the signals are processed in 48-bit word length. The dynamic range is more than 117 dB.

MI-1



MI-1 The MI-1 is an eight-channel Microphone Input Module for the NetMax™ System Controller. The module provides a variety of microphone input functions, e. g. programmable gain, software-switchable PAD for line sensitivity and selectable +48V phantom supply per input channel. Best audio performance is achieved by high-end linear 24-bit converters. Internally the signals are processed in 48-bit word length. The dynamic range is more than 117 dB.

DI-1



DI-1 The DI-1 is an eight-channel Digital Input Module for the NetMax™ System Controller. The module can handle digital audio signals in AES/EBU, S/PDIF and optical formats. Electrical AES/EBU and S/PDIF signals are connected via screw lockable Euro block connectors. Optical signals are connected to Toslink™ input sockets. Sample rate converters on all input channels allow independent connection of digital audio sources with sample rates from 32 kHz to 192 kHz.

AO-1



AO-1 The AO-1 is an eight-channel analog output module for the NetMax™ System Controller. As with the other modules, the AO-1 offers eight high quality audio signals via screw-lockable Euro block connectors. D-to-A conversion is handled by high performance linear 24-bit converters. Internally the signals are processed in 48-bit word length. The dynamic range is more than 118 dB.

CM-1



CM-1 The CM-1 is a CobraNet™ Extension Module for the NetMax™ System Controller. The module provides 32 input and 32 output FULLY LICENSED channels of CobraNet™ compatible audio signals for extending the system capability.

DSP-1



DSP-1 The DSP-1 is a DSP Extension Module for the NetMax™ System Controller. The module provides additional DSPs for extending the signal processing capacity and RAM banks to provide the power to create longer delay times or additional delay lines among other functions.

AMPLIFIERS

EV bietet eine große Auswahl an Endstufen für jedes NetMax-System

RL Series

EV's RL Series DSP-Controlled amplifiers are tightly integrated into the IRIS-Net™ platform. They are the ideal companion to the NetMax™ N8000 system controller and combine legendary performance with uncompromised remote control and system supervision capability. When you need DSP power in multiple locations, the RL line is the state-of-the-art choice. They employ EV's proven signal processor technologies, and they guarantee superior audio performance.

P3000 RL

The flagship of the RL Series, with 2 x 1300 watts into 4 ohms and 2 x 1800 watts into 2 ohms, is the digital controlled version of the legendary P3000 amplifier. Loudspeaker outputs on Neutrik® Speakon® NL4 connectors.

P1200 RL / RT

The universally recognized P1200RL features with 2 x 600 watts into 4 ohms and 2 x 850 watts into 2 Ohms. Loudspeaker outputs on barrier strip.

For the RT model, the unit features a high-impedance output for 100/70V-lines with 2 x 590 watts.

P900 RL / RT

Featuring 2 x 450 watts into 4 ohms and 2 x 650 watts into 2 ohms, the P900RL is ideal for HF drive in multi-way systems. Loudspeaker outputs on barrier strip.

For the RT model, the unit has a high-impedance output for 100/70V-lines with 2 x 410 watts. Loudspeaker outputs on barrier strip.



RL Series Specifications

	P900 RL			P1200 RL			P3000 RL			P900 RT		P1200 RT	
Load Impedance	8Ω	4Ω	2Ω	8Ω	4Ω	2Ω	8Ω	4Ω	2Ω	100V	70 V	100V	70 V
Continuous Output Power (1 kHz, THD 1%)	280 W	450 W	650 W	380 W	600 W	850 W	850 W	1300 W	1800 W	410 W	400 W	590 W	580 W
Rated Output Power (20 Hz-20 kHz, THD <0.2%)	230 W	350 W	450 W	300 W	500 W	650 W	750 W	1200 W	1500 W	350 W	350 W	500 W	500 W
THD @ Rated Output Power	<0.05%									<0.1%	<0.2%	<0.1%	<0.2%
Intermodulation (SMPTE)	<0.08%						<0.01%			<0.1%	<0.3%	<0.1%	<0.3%
Signal to Noise Ratio	>105 dB									>100 dB			
Frequency Response (-1 dB)	20 Hz - 20 kHz									45 Hz - 20 kHz			
Dynamic Audio Limiter	THD <= 1% (Input signal <= + 20 dBu)												
Protections	Hi-Temperature, DC, HF, Back EMF, Peak Current Limiter, Inrush Current Limiter, Power On Delay												
Cooling	3(4)-stage fan, front-to-rear cooling												
Input Sensitivity and Impedance	1.55 V (+6dBu), 20 kOhm, XLR Input												
Maximum Input Level	8.7 V (+21 dBu)												
Serial Interface	Network: CAN, 2 RJ45 (CAT-5 Cabling), RS-232 for media control systems												
Control Logic in and Outputs	2 x 0V - 5V, free configurable, Easy-Remote												
Loudspeaker Connectors	Barrier Strip						Neutrik® Speakon® NL4			Barrier Strip			
Dimensions (Height x Width x Depth)	5.2" x 19" x 15.4" (132.5 x 483 x 390 mm) (3 RU)												
Net Weight	35.3 lbs (16 kg)			37.5 lbs (17 kg)			66.2 lbs (30 kg)			53 lbs (24 kg)		55.1 lbs (25 kg)	

The CPS Class-H High Efficiency Series

In any NetMax™ system, when onboard DSP and supervision is not required, these proven power amplifiers offer our legendary performance and reliability in a new compact, lightweight format. This is made possible by incorporating a highly efficient Class-H design, which results in substantially less heat being generated. This allows the overall size of the amplifier to be reduced substantially without sacrificing performance or reliability.

All four models are capable of remote control activation with adjustable power-on delay times saving time and money in larger installs with central power distribution. These features make them ideal amplifiers to a NetMax™ N8000 system where central DSP processing is desired. The specifications speak for themselves. Four models are available ranging from 400 watts/channel all the way up to 1100 watts per channel into 4 ohms.



CPS 2.4

The CPS2.4 is ideal for smaller full range systems or larger mid/high frequency amplification in larger installations. The CPS2.4 is an ideal companion to the popular EVID line of premium surface mount and ceiling speaker systems.

CPS 2.6

The workhorse of the line. Its 600 watts of compact power is perfect for mid level full range installs.

CPS 2.8

At 800 watts per channel the CPS2.8 is the best values in the line. It can power a wide range of speaker cabinets either in multi-way or full range modes for a large range of fixed installation jobs.

CPS 2.11

No power amplifier on the market can offer such a high level of power performance and reliability. At 1100 watts/channel the CPS2.11 can power large stadium, theatre and auditorium type installations with ease.

CPS Series Amplifier Specifications

	CPS 2.4			CPS 2.6			CPS 2.8			CPS 2.11		
Load Impedance	2Ω	4Ω	8Ω	2Ω	4Ω	8Ω	2Ω	4Ω	8Ω	2Ω	4Ω	8Ω
Continuous Output Power (1 kHz, THD 1%)	600W	400W	240W	900W	600W	350W	1100W	800W	500W	1600W	1100 W	600W
Rated Output Power THD = 0.1 %, 20 Hz-20kHz	-	300W	150W	-	500W	250W	-	700W	350W	-	900W	450W
Input Sensitivity Rated power @ 8 Ω, 1 kHz	+1.15 dBu (0.88 Vrms)			+3.2 dBu (1.12 Vrms)			+4.7 dBu (1.33 Vrms)			+5.8 dBu (1.51 Vrms)		
THD @ rated output power (<0.1%)	< 0.05 %											
IDE- SMTP 60 Hz, 7kHz	< 0.02 %											
Maximum Input Level	+22 dBu (9.76 Vrms)											
Crosstalk ref. 1 kHz, rated output power	< -80 dB											
Frequency Response ref. 1 kHz	15 Hz ... 40 kHz (±1dB)											
Damping Factor 1 kHz	> 300											
Slew Rate	35 V/μs											
Signal to Noise Ratio (A-weighted)	103.5 dB			105.5 dB			107 dB			107 dB		
Power Requirement	240 V, 230 V, 220 V, 120 V or 100 V ; 50 ... 60 Hz (factory configured)											
Net Weight	30.8 lbs (13.5 kg)			33 lbs (15 kg)			35.2 lbs(16 kg)			17.96 lbs (8.15 kg)		
Dimensions (Width x Height x Depth)	19" x 3.5" x 15.22" (483 mm x 88.1 mm x 386.8 mm)											

NetMax™ N8000 Specifications

GENERAL DESCRIPTION AND FEATURES	
N8000 System Controller	Modular NetMax™ system manager including signal processing, routing, system control and supervision
Audio	32 Audio Channels. 4 Audio Slots, modular. 8-Channel Input and Output cards, analog or digital.
Networking	Module Slot for optional CobraNet™ Interface. 32 I/O Audio and Control.
Safety / Redundancy	Internal Supervision, System Monitoring, Watchdog, Fault Output, Redundant Audio Network possible
PC Configuration and Control Software	IRIS - Intelligent Remote & Integrated Supervision. Integration of N8000, Remote Amplifiers and Peripheral Control. Configuration, Control and Supervision for complete Audio Systems. Freely programmable User Control Panels and Access Levels.
AUDIO SPECIFICATIONS	
Audio Inputs	8 analog audio inputs per module, line level, electronically symmetric
Input Connectors	8 x 3-pole Euro block connectors
Input Level (nominal)	+6 dBu / 1.55 V
Input Level (max. before clip)	+21 dBu / 8.7 V
Input Impedance	20 kΩ
Common Mode Rejection	> 70 dB
A/D Conversion	24 Bit, Sigma-Delta, 128 times over sampling
Audio Outputs	8 analog audio outputs per module, line level, electronically symmetric
Connectors	8 x 3-pole Euro block connectors
Output Level (nominal)	+6 dBu / 1.55 V
Output Level (max. before clip)	+21 dBu / 8.7 V
Output Impedance	100 Ω
Min. Load Impedance	600 Ω
D/A Conversion	24 Bit, Sigma-Delta, 128 times over sampling
Frequency Response	20 Hz...20 kHz (-0.5 dB)
Signal to Noise Ratio (A-weighted)	AI-1: 117 dB typical, AO-1: 118 dB typical, N8000 analog In to analog Out: 115 dB typical
THD+N	< 0.005 %
Signal Delay	AI-1: 1.3958 ms AO-1: 0.646 ms N8000 analog In to analog Out: 2.2917 ms
Crosstalk	< -110 dB @ 1 kHz
SIGNAL PROCESSING	
Sample Rate	48 kHz internal, 32 kHz - 192 kHz external
Data Format	24 Bit linear A/D and D/A conversion, 48 Bit processing
Signal Processing	2 DSPs Standard (150MHz, 300 MIPS), 1 DSP per Audio Module (100MHz, 100 MIPS), DSP-1 Extension Module optional (+300 MIPS)
INTERFACES	
Ethernet	10 / 100 MBit/s, RJ-45 (PC Control)
CAN	10 ... 500 kbaud, 2 x RJ-45 (Remote Amp Control)
RS-232	2 Ports, 9 pin DSUB female (Remote Control)
USB	USB Type B on Front Panel (PC Control)
GPIO Control Port	2 x 6-pole Euro block, 4 Control Inputs (analog 0 -10V / logic control), 3 Control Outputs (Relay contact to ground), 1 Fault Output (NC Relay contact), 3 Reference Outputs (+5V, +10V / GND)
N8000 GENERAL SPECIFICATIONS	
Power Supply	100 - 240 V AC, 50/60 Hz
Power Consumption	90 W max. (incl. 2 x AI-1, 2 x AO-1, 1 x CM-1 modules)
Cooling	Left-to-right, 3-stage fan
Operating Temperature Range	32°F – 104°F (0 °C – 40 °C)
Dimensions (W x H x D)	19" x 3.5" x 15" (483 x 88.1 x 381 mm) 2 RU
MODULES / OPTIONS	
AI-1 Analog Input Module	8 analog audio inputs, line level, electronically symmetric
AO-1 Analog Output Module	8 analog audio outputs, line level, electronically symmetric
CM-1 CobraNet™ Module	32 digital audio inputs and outputs, 2 CobraNet™ ports (Primary/Secondary) for network redundancy
DSP-1 DSP Extension Module	Internal DSP processing power and Delay-RAM extension, 300 MIPS, 256k x 24 SRAM
MI-1 Microphone Input Module	8 microphone inputs, programmable Gain and Phantom Power, PAD for line level switching
DI-1 Digital Input Module	8 digital audio inputs. AES/EBU and S/PDIF and optical formats. sample rate converters for 32-192 kHz operation

Americas

Telex Communications Inc.
12000 Portland Ave South,
Burnsville, MN 55337, USA
USA: Phone: 1-800-392-3497
Fax: 1-800-955-6831
Canada: Phone: 1-866-505-5551
Fax: 1-866-336-8467
Latin America: Phone: 1-952-887-5532
Fax: 1-952-736-4212

Europe, Africa & Middle-East

Germany: EVI Audio GmbH,
Hirschberger Ring 45,
D-94315 Straubing, Germany
Phone: +49 9421 706-0
Fax: +49 9421 706-265

France: EVI Audio France S.A.,
Parc de Courcerin,
Allée Lech Walesa,
F 77185 Lognes, France
Phone: +33 1-6480-0090
Fax: +33 1-6006-5103

UK: Shuttlesound,
4 The Willows Centre,
Willow Lane, Mitcham,
Surrey CR4 4NX, UK
Phone: +44 208 646 7114
Fax: +44 208 254 5666

Asia & Pacific Rim

Japan: EVI Audio Japan Ltd.
5-3-8 Funabashi, Setagaya-Ku,
Tokyo, Japan 156-0055
Phone: +81 3-5316-5020,
Fax: +81 3-5316-5031

China: Telex EVI Audio (Shanghai) Ltd.
Room 2210-2215,
Tower B, Far East International Plaza
No. 317, Xianxia Road,
Shanghai, China, PC: 200051
Phone: +86 (21) 6235-1677
Fax: +86 (21) 6235-1676

Hong Kong: Telex EVI Audio (HK) Ltd.
Unit 5,1/F, Topsail Plaza
11 On Shum Street
Shek Mun, Shatin HK
Phone: +852 2351-3628
Fax: +852 2351-3329

Singapore: Telex Pte. Ltd.
3015A Ubi Road 1, 05-10
Kampong Ubi Industrial Estate,
Singapore 408705
Phone: +65 6746-8760
Fax: +65 6746-1206